

KN3D05120A

Silicon Carbide Schottky Diode

V_{RRM}	=	1200 V
$I_F (T_c=158\text{ }^\circ\text{C})$	=	5 A
Q_c	=	37 nC

Features

- 1.2kV Schottky Rectifier
- Zero Reverse Recovery Current
- High-Frequency Operation
- Temperature-Independent Switching
- Extremely Fast Switching

Benefits

- Replace Bipolar with Unipolar Rectifiers
- Essentially No Switching Losses
- High Efficiency
- Reduction of Heat Sink Requirements
- Parallel Devices Without Thermal Runaway

Applications

- Switch Mode Power Supplies
- Power Factor Correction
- Motor Drives

Package

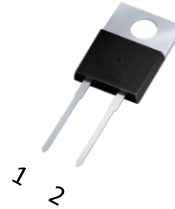

TO-220-2



Part Number	Package	Marking
KN3D05120A	TO-220-2	KN3D05120A

Maximum Ratings (T_c = 25 °C unless otherwise specified)

Symbol	Parameter	Value	Unit	Test Conditions	Note
V_{RRM}	Repetitive Peak Reverse Voltage	1200	V		
V_{RSM}	Surge Peak Reverse Voltage	1300	V		
V_R	DC Peak Reverse Voltage	1200	V		
I_F	Continuous Forward Current	20 9.7 5	A	T _c =25 °C T _c =135 °C T _c =158 °C	Fig. 3
I_{FSM}	Non-Repetitive Forward Surge Current	55	A	T _c =25 °C, t _p =10 ms, Half Sine Pulse	
P_{tot}	Power Dissipation	117 51	W	T _c =25 °C T _c =110 °C	Fig. 4
T_J	Operating Junction Range	-55 to +175	°C		
T_{stg}	Storage Temperature Range	-55 to +175	°C		

Electrical Characteristics

Symbol	Parameter	Typ.	Max.	Unit	Test Conditions	Note
V_F	Forward Voltage	1.38 2	1.65 2.5	V	$I_F = 5\text{ A}$, $T_J = 25\text{ }^\circ\text{C}$ $I_F = 5\text{ A}$, $T_J = 175\text{ }^\circ\text{C}$	Fig. 1
I_R	Reverse Current	2 11	50 200	μA	$V_R = 1200\text{ V}$, $T_J = 25\text{ }^\circ\text{C}$ $V_R = 1200\text{ V}$, $T_J = 175\text{ }^\circ\text{C}$	Fig. 2
Q_c	Total Capacitive Charge	37		nC	$V_R = 800\text{ V}$, $I_F = 5\text{ A}$, $T_J = 25\text{ }^\circ\text{C}$	Fig. 6
C	Total Capacitance	410		pF	$V_R = 0\text{ V}$, $T_J = 25\text{ }^\circ\text{C}$, $f = 1\text{ MHz}$	Fig. 5
		36			$V_R = 400\text{ V}$, $T_J = 25\text{ }^\circ\text{C}$, $f = 1\text{ MHz}$	
		26			$V_R = 800\text{ V}$, $T_J = 25\text{ }^\circ\text{C}$, $f = 1\text{ MHz}$	
E_c	Capacitance Stored Energy	9.5		μJ	$V_R = 800\text{ V}$	Fig. 7

Note: This is a majority carrier diode, so there is no reverse recovery charge.

Thermal Characteristics

Symbol	Parameter	Min.	Typ.	Max.	Unit	Note
$R_{\theta JC}$	Thermal Resistance from Junction to Case		1.28		$^\circ\text{C/W}$	Fig. 8

Typical Performance

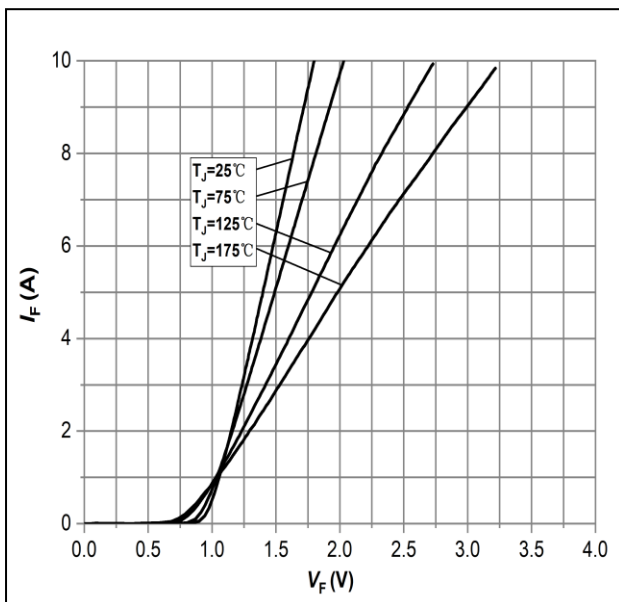

Figure 1: Forward Characteristics

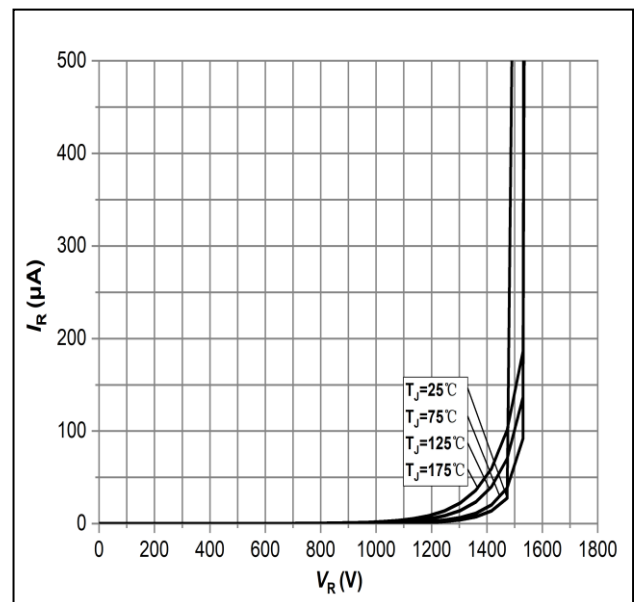

Figure 2: Reverse Characteristics

Typical Performance

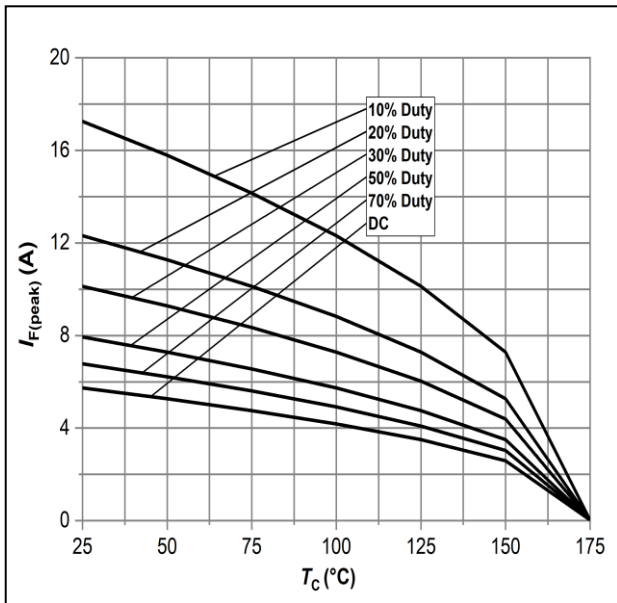

Figure 3: Current Derating

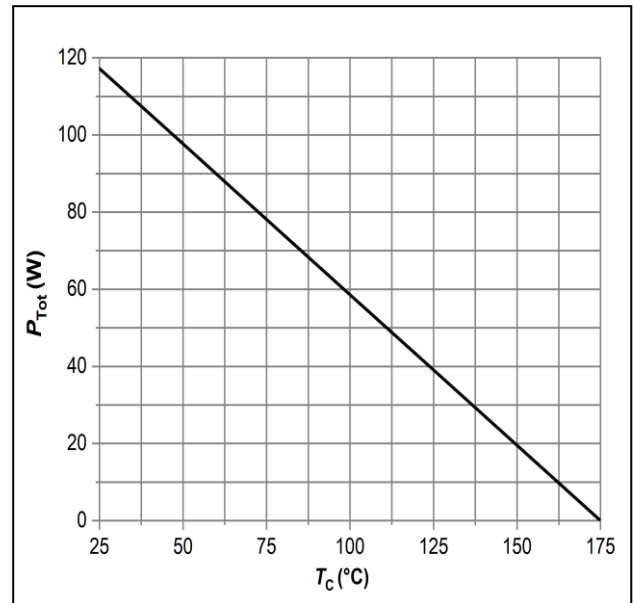

Figure 4: Power Derating

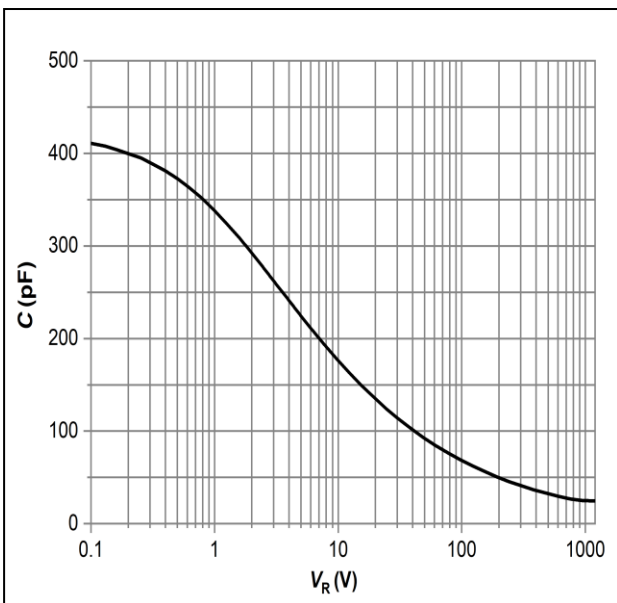

Figure 5: Capacitance vs. Reverse Voltage

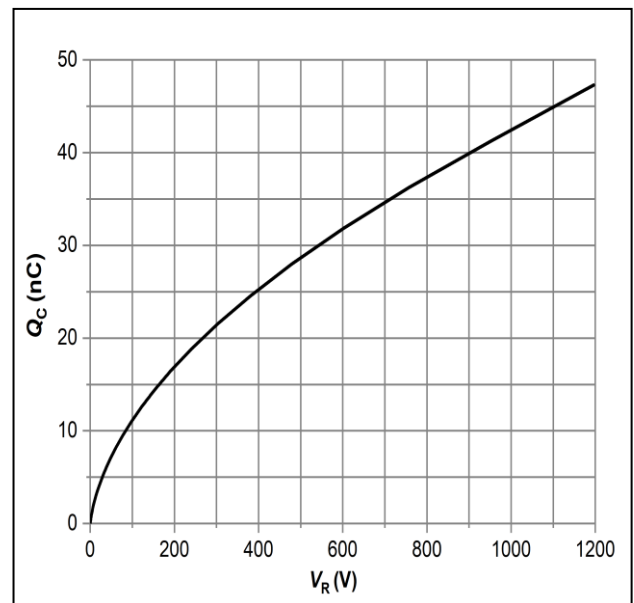

Figure 6: Total Capacitance Charge vs. Reverse Voltage

Typical Performance

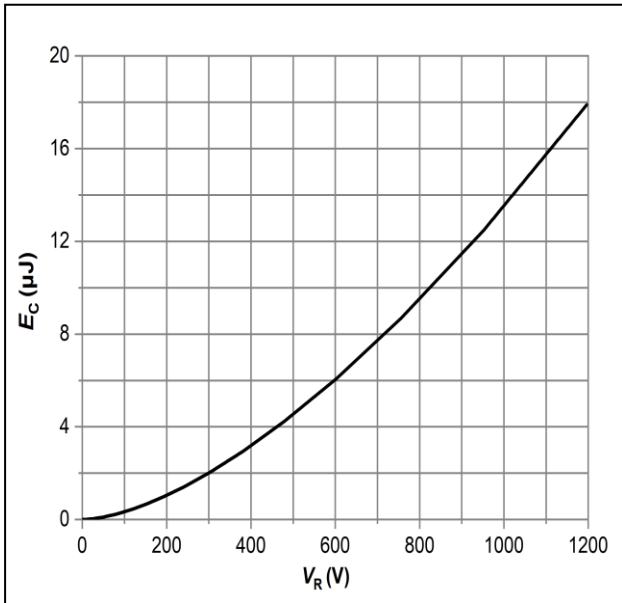

Figure 7: Typical Capacitance Stored Energy

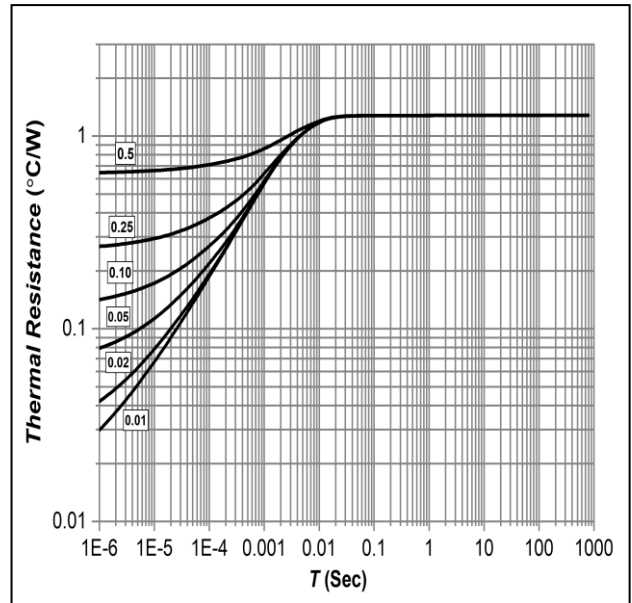
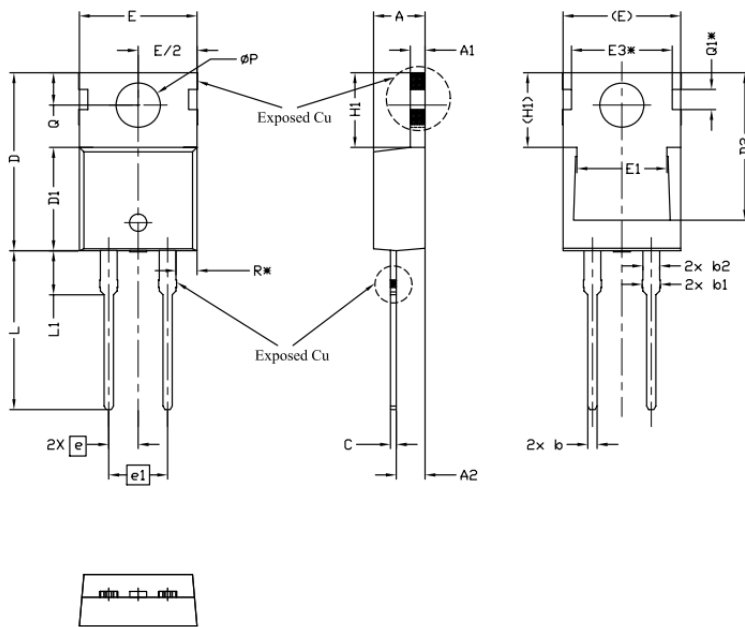

Figure 8: Transient Thermal Impedance

Package Dimensions

Package: TO-220-2



SYMBOL	DIMENSIONS			NOTES
	Min.	NOM	Max.	
A	4.24	4.44	4.64	
A1	1.15	1.27	1.40	
A2	2.30	2.48	2.70	
b	0.70	0.80	0.90	
b1	1.20	1.55	1.75	
b2	1.20	1.45	1.70	
c	0.40	0.50	0.60	
D	14.70	15.37	16.00	4
D1	8.82	8.92	9.02	
D2	12.43	12.73	12.83	5
E	9.96	10.16	10.36	4.5
E1	6.86	7.77	8.89	5
E3*	8.70 REF			
e	2.54 BSC			
e1	5.08 BSC			
H1	6.30	6.45	6.60	5.6
L	13.47	13.72	13.97	
L1	3.60	3.80	4.00	
ϕP	3.75	3.84	3.93	
Q	2.60	2.80	3.00	
Q1*	1.73 REF			
R*	1.82 REF			

NOTE : Dimension L, M, W apply for Solder Dip Finish